



## **testo 160**

### **Online data loggers**

0572 2019 – testo 160 T

0572 2021 – testo 160 TH

0572 2022 – testo 160 E

User manual





# Contents

<b>1</b>	<b>About this document .....</b>	<b>5</b>
<b>2</b>	<b>Safety and disposal.....</b>	<b>5</b>
2.1	Security .....	5
2.2	Disposal .....	6
<b>3</b>	<b>Intended use .....</b>	<b>7</b>
<b>4</b>	<b>Product description .....</b>	<b>8</b>
4.1	System overview .....	8
4.2	testo Account.....	9
4.3	Online data loggers .....	9
4.3.1	testo 160 T .....	9
4.3.2	testo 160 TH.....	9
4.3.3	testo 160 E.....	11
4.4	External probes .....	11
4.4.1	S-TH.....	11
4.4.2	S-LuxUV.....	12
4.4.3	S-Lux.....	13
4.4.4	Extension cable.....	13
4.5	Deco-covers .....	13
<b>5</b>	<b>First steps .....</b>	<b>14</b>
5.1	Creating a testo Account .....	14
5.2	Putting the data logger into operation.....	14
5.3	Integrating data loggers into testo Account .....	15
5.3.1	Commissioning via testo Smart App.....	16
5.3.2	Commissioning via testo Smart Connect Cloud (via USB cable) .....	16
5.3.3	Offline configuration via PDF (via USB-cable).....	17
5.4	License.....	18
5.5	Configuration and operation of online-data loggers.....	18
<b>6</b>	<b>Using the product.....</b>	<b>19</b>
6.1	Inserting into/removing from the wall bracket .....	19
6.1.1	Installing the probe on the data logger .....	19
6.1.2	Deco-cover installation .....	20
6.1.3	Wall bracket installation.....	20
<b>7</b>	<b>Maintaining the product.....</b>	<b>21</b>
7.1	Cleaning the instrument .....	21
7.1.1	Changing batteries .....	21
<b>8</b>	<b>Technical data .....</b>	<b>22</b>
8.1	Online data loggers .....	22

## Contents

---

8.2	External probes.....	25
8.3	Deco-covers.....	26
<b>9</b>	<b>Tips and assistance.....</b>	<b>27</b>
9.1	Questions and answers .....	27
9.2	Status LED signals .....	28
9.2.1	Key functions .....	29

# 1 About this document

- The instruction manual is an integral part of the instrument.
- Keep this documentation at hand so that you can refer to it when necessary.
- Always use the complete original instruction manual.
- Please read this instruction manual through carefully and familiarize yourself with the product before putting it to use.
- Hand this instruction manual on to any subsequent users of the product.
- Pay particular attention to the safety instructions and warning advice in order to prevent injury and damage to the product.

## 2 Safety and disposal

### 2.1 Security

#### General safety instructions

- Only operate the product properly, for its intended purpose, and within the parameters specified in the technical data.
- Do not apply any force.
- Do not operate the instrument if there are signs of damage to the housing or connected cables.
- Dangers may also arise from objects to be measured or the measuring environment. Always comply with the locally valid safety regulations when carrying out measurements.
- Do not store the product together with solvents.
- Do not use any desiccants.
- Only perform maintenance and repair work on this instrument that is described in this documentation. Follow the prescribed steps exactly when doing the work.
- Use only original spare parts from Testo.

#### Batteries

- Improper use of batteries may cause the batteries to be destroyed, or lead to injury due to current surges, fire or escaping chemicals.
- Only use the batteries supplied in accordance with the instructions in the instruction manual.
- Do not short-circuit the batteries.
- Do not take the batteries apart and do not modify them.

## 2 Safety and disposal

---

- Do not expose the batteries to heavy impacts, water, fire or temperatures in excess of 60 °C.
- Do not store the batteries in the proximity of metal objects.
- Do not use any leaky or damaged batteries.
- In the event of contact with battery acid: rinse affected areas thoroughly with water, and if necessary consult a doctor.
- Do not use any leaky or damaged batteries.

### Warnings

Always pay attention to any information denoted by the following warnings. Implement the precautionary measures specified!

 **DANGER**

Risk of death!

---

 **WARNING**

Indicates possible serious injury.

---

 **CAUTION**

Indicates possible minor injury.

---

**ATTENTION**

Indicates possible damage to equipment.

---

## 2.2 Disposal

- Dispose of faulty rechargeable batteries and spent batteries in accordance with the valid legal specifications.
- At the end of its useful life, deliver the product to the separate collection point for electric and electronic devices (observe local regulations) or return the product to Testo for disposal.



■ WEEE Reg. No. DE 75334352

### 3 Intended use

The testo 160 online data loggers are used for storing and reading out individual readings and series of measurements.

The testo 160 online data loggers record measurement values (temperature and humidity, lux and UV) and send them directly to the testo Smart Connect Cloud via a WLAN connection.



The humidity sensor testo 160 TH and the external probe S-TH may not be used in dust environment as the sensor could be polluted.

The sensor is susceptible to pollutants and must be protected from exposure to volatile chemicals, acids, bases and cleaning agents.

---

# 4 Product description

## 4.1 System overview

The testo 160 online data logger system is the modern solution for monitoring temperature and humidity values. Other measurement variables such as CO<sub>2</sub>, atmospheric pressure, lux and UV can also be measured.

The testo 160 online data logger system consists of the hardware components (testo 160, testo 162, testo 164) as well as the testo Smart Connect Cloud (logins | Testo SE & Co. KGaA) and testo Smart App. The testo Smart Connect Cloud is the central data platform. Measurement values can be viewed and analyzed there.

The testo 160, testo 162 and testo 164 products offer you maximum flexibility thanks to their wide range of variants and can be easily combined and expanded in your testo account.

Retrieve measured values on any end device

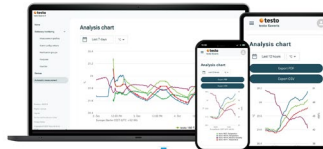

Storage of measured values in the Testo Cloud

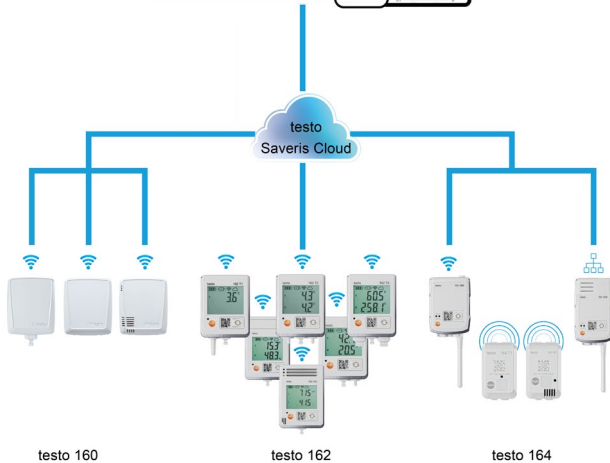

Measurement value recording with online data loggers

If limit values are exceeded, you can be alerted directly via push notification of limit value violations thanks to the testo Smart App. Alternatively, you can be notified by email or SMS.

You can access all measurement values and analysis functions anytime and anywhere using your internet-enabled smartphone, tablet or PC.

A valid license must be purchased to operate the online data logger in the cloud (Data Monitoring License).

## 4.2 testo Account

The online data loggers (testo 160, testo 162, testo 164) require an associated testo account to ensure operation.

Each data logger operated there requires a testo Data Monitoring license.

## 4.3 Online data loggers

### 4.3.1 testo 160 T



You can use the testo 160 T online data logger to carry out temperature measurements.

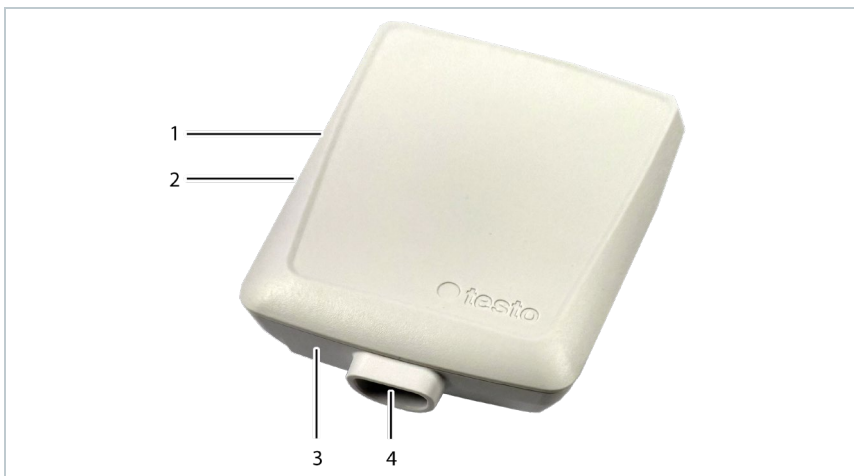

Element	Element
<b>1</b> Status LED	<b>2</b> Button
<b>3</b> Internal sensor for temperature	<b>4</b> Micro USB port

### 4.3.2 testo 160 TH



You can use the testo 160 TH data logger to carry out temperature and humidity measurements.

## 4 Product description

---

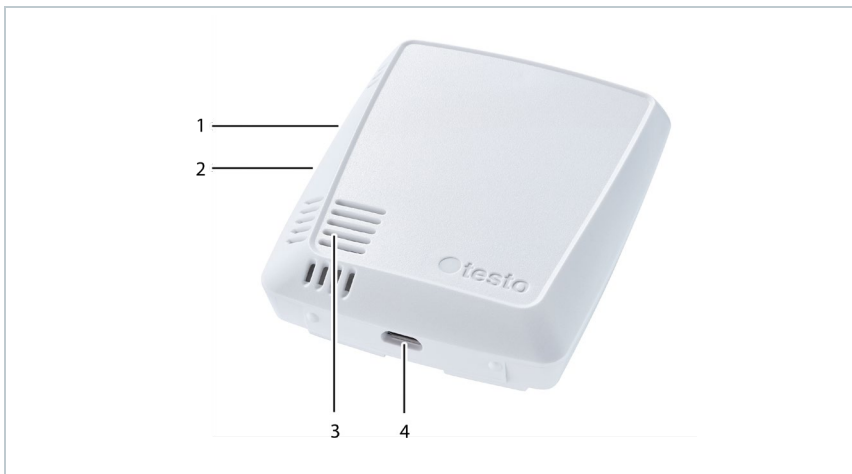

Element		Element	
<b>1</b>	Status LED	<b>2</b>	Button
<b>3</b>	Internal sensors for temperature and relative humidity	<b>4</b>	Micro USB port

### 4.3.3 testo 160 E



The external probes S-TH, S-LuxUV and S-Lux can be connected to the testo 160 E testo 160 E online data logger.



Element		Element	
1	Status LED	2	Button
3	Connector socket for external sensor	4	Micro USB port
5	Connector socket for external sensor		

## 4.4 External probes

The external sensors S-TH, S-LuxUV and S-Lux together with the online data logger 160 E form a very flexible measuring system.



The external probes are only approved in conjunction with the testo 160 E online data logger.

### 4.4.1 S-TH



The external probe S-TH can be connected to the online data logger testo 160 E. You can use the S-TH probe to carry out temperature and humidity measurements.



To make it easy to install, the probe can be pushed out of the wall bushing. The probe can also be used without this wall bushing.

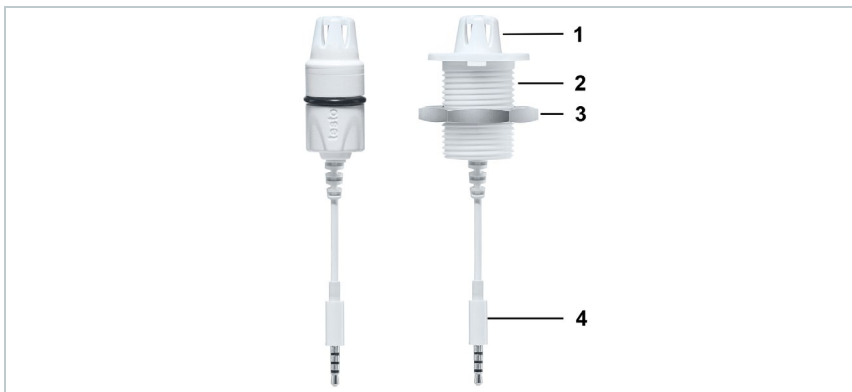

Element	Element
1 Sensor	2 Screw thread of the wall bushing
3 Securing nut	4 Jack plug

### 4.4.2 S-LuxUV



The external probe S-LuxUV can be connected to the online data logger testo 160 E. You can use the S-LuxUV probe to carry out illuminance and UV measurements.

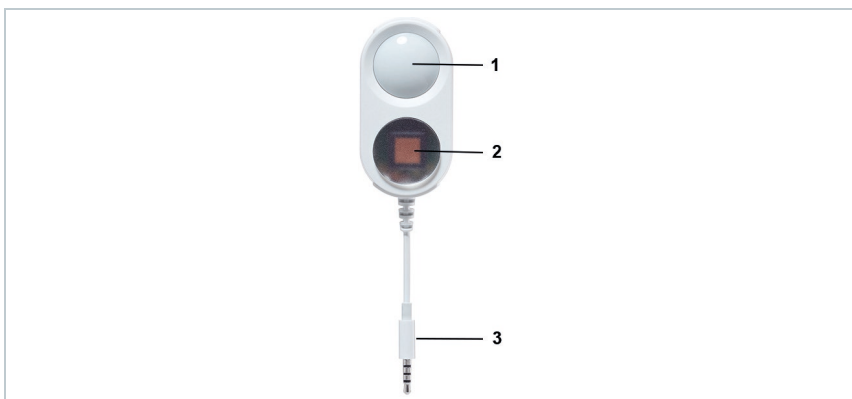

Element	Element
1 Lux sensor	2 UV sensor
3 Jack plug	

### 4.4.3 S-Lux



The external probe S-Lux can be connected to testo 160 E online data logger. You can use the S-Lux probe to carry out illuminance measurements.



Element	Element
1 Lux sensor	2 Jack plug

### 4.4.4 Extension cable



The sensors are supplied with the 60 cm cable (0554 2004) as standard. A 2.5 m long cable is optionally available (0554 2005), to be able to adapt the measurement system to all measuring situations. Since these are digital probes, multiple extension cables can also be combined. The maximum total length is approx. 10 m.

## 4.5 Deco-covers

The optional cover 0554 2006 is intended for the testo 160 TH and testo 160 E online data loggers.

## 5 First steps

### 5.1 Creating a testo Account

If you do not yet have a testo account, register at:  
<https://www.testo.com/en/login/logins>

Registration is also possible via the testo Smart App.



The testo Smart App is available for iOS devices in the AppStore or for Android devices in the Play Store.

Compatibility:

Requires iOS 13.0 or newer / Android 8.0 or newer,  
requires Bluetooth® 4.2.2.



### 5.2 Putting the data logger into operation



The external probes must be connected to the testo 160 E online data logger **before** logging on to the cloud for the first time. If an additional probe is to be connected later, the online data logger must first be logged out of the cloud. The external probe can then be connected and the online data logger can be logged in again.

#### ATTENTION

##### Damage to the online data logger!

- Do not bring near solvents.
- Do not clean with solvent.

#### ATTENTION

##### Damage to optical surfaces possible (S-Lux and S-LuxUV)

- Do not use sharp objects.
- Only use soft cleaning cloths.
- Do not use aggressive cleaning agents.

- 1 Remove the online data logger from the packaging.
- 2 Remove the online data logger from the wall bracket.
- 3 For online data loggers with external sensors:  
Connect the sensor to the intended location.

- 4 For testo 160 T:  
Loosen the battery cover by slightly loosening the screws on the back of the housing.

For testo 160 TH and testo 160 E:  
Open the battery compartment cover.



- 5 Remove battery safety strips.







If the data logger is to be used at temperatures below +10 °C, replace the existing batteries with lithium batteries (0515 1042).

- ▶ The online data logger is now activated.
- 6 Close the battery compartment.

### Optional mains operation

The testo 160 online data loggers can also be powered via the USB port instead of being run on batteries. However, the online data loggers do not have a charging function, i.e. no rechargeable batteries in the online data logger can be charged up via the USB port. If you connect the online data logger to the USB port on your PC, the online data logger automatically switches to mass storage and configuration mode. A PC is therefore not suitable as a voltage source for logger operation.

### Symbol explanation

	Do not allow children under 6 years of age to play with batteries.
	Do not throw batteries in the trash.
	Do not charge batteries.
	Do not place batteries near fire.
	Batteries are recyclable.

## 5.3 Integrating data loggers into testo Account

There are several ways to integrate the online data loggers into your network and into your testo account:

- Commissioning via testo Smart App (via WLAN hotspot)
- Commissioning via desktop computer and testo Smart Connect Cloud (via USB cable)
- Offline commissioning via PDF (via USB cable)



In networks with WPA2 Enterprise encryption, commissioning via the testo Smart App is not possible.

---

### 5.3.1 Commissioning via testo Smart App

---



To establish a connection via WiFi hotspot, you need a tablet or smartphone with the Testo Smart App already installed on it.

You can get the App for iOS instruments in the App Store or for Android instruments in the Play Store.

Compatibility:

Requires iOS 13.0 or later / Android 8.0 or later.



- 1 | Open testo Smart App.
- 2 | Select the application **Monitoring**.
- 3 | Login or register in the testo account.
- 4 | Select **Commissioning**.
- 5 | Follow the step-by-step instructions.

### 5.3.2 Commissioning via testo Smart Connect Cloud (via USB cable)

- 1 | Open testo Smart Connect Cloud: [www.smartconnect.testo.com](http://www.smartconnect.testo.com)
- 2 | Log in to your testo account or register again.
- 3 | Select **Register online data logger**.
- 4 | Follow the step-by-step instructions.

### 5.3.3 Offline configuration via PDF (via USB-cable)

As an alternative to creating the configuration file in the Quick Start Guide with subsequent download of the XML configuration file, the WiFi data logger can also be configured via a PDF form.



You need the Adobe Reader program (version 10 or later) to use the PDF form correctly. If you have not installed Adobe Reader, you can go to the following address to download it free of charge:  
<http://get.adobe.com/reader/>.

- ✓ Make sure that the batteries are inserted.
- 1 Connect the online data logger to the PC via USB connection.
- 2 Open the file **WiFiConf.pdf** on the external drive "testo 160".
- 3 Copy your Account ID and paste it into the relevant field on the PDF form.  
You will find the Account ID in the **Account and settings**.



The testo 160 online data loggers can be configured for up to three WLAN networks. Network name (SSID), password and security settings can be stored for each profile.

- 4 Enter the **Network name (SSID)** and, if necessary, your **WLAN password** in the relevant fields on the PDF form.
- 5 Click on the **Save configuration** button.
- ▶ A dialogue opens for exporting the form data.
- 6 Select the external drive testo 160 as the storage location and save the form data (configuration file **WiFiConf\_Daten.xml**) on it.
- ▶ The green and red LEDs light up simultaneously until the PDF document is completely generated.
- 7 Disconnect the USB connection to the PC to complete the configuration of the data logger.
- 8 Check whether the online data logger is shown within 15 min in your could account in **Online Data Logger**.



You can also save the configuration file locally on your computer. Other online data loggers can be configured even faster by simply copying the XML configuration file onto the external drive testo 160.

---

### 5.4 License

After successfully commissioning the data loggers, you must book a valid license for operating the data loggers in the testo Smart Connect Cloud.

---



Make sure that you have a valid license for each data logger.

---

- 1 | Open testo Cloud Account (in the testo Smart App or directly in the testo Smart Connect Cloud).
- 2 | Open **testo Subscription Portal**.

### 5.5 Configuration and operation of online-data loggers

The testo 160, testo 162 and testo 164 online data loggers can only be used and operated in conjunction with the testo Smart Connect Cloud.

Information on operating the data loggers (configuration, limit values, alarms, etc.) can be found in the notes and info boxes in the testo Smart Connect Cloud.

## 6 Using the product

### 6.1 Inserting into/removing from the wall bracket

- 1 Insert the unlocking tool into the unlocking opening.



- 2 Push back the locking pin using the unlocking tool.

- 3 Pull the data logger up and out of the wall bracket.



#### 6.1.1 Installing the probe on the data logger



The external probes must be connected to the online data logger **before** logging into the Cloud for the first time. If an additional probe is to be connected at a later stage, the data logger must first be logged out of the Cloud. The external probe can then be connected and the data logger logged in again.

- 1 Connect the probe plug to the designated jack on the data logger.



- ▶ The external probe is ready for use.

### 6.1.2 Deco-cover installation

- 1 Break out the required, pre-punched knock-out points on the deco-cover.
- 2 Place the deco-cover onto the data logger from the side and press it into place.
- 3 Always make sure that the deco-cover is positioned correctly so as not to obscure sensors.
- 4 Then connect external probes or the external voltage supply once again.

#### CAUTION

##### **Incorrect readings!**

- Make sure that the deco-cover is positioned correctly.

#### CAUTION

##### **Damage to the sensor!**

- Let painted or varnished deco-covers dry out and out-gas sufficiently before fitting.

### 6.1.3 Wall bracket installation



The wall bracket supplied, which comes with an adhesive pad, is only intended for testo 160 loggers and ensures that the loggers stay securely in place. Any other use is not deemed appropriate and may result in the wall bracket being damaged.



Apart from the adhesive pad, no other mounting materials are included in the delivery. Please select suitable mounting materials (cable ties or screws) that are appropriate for the required mounting location.

# 7 Maintaining the product

## 7.1 Cleaning the instrument

- 1 | If the housing of the instrument is dirty, clean it with a damp cloth.



Do not use any aggressive cleaning agents or solvents! Mild household cleaning agents and soap suds may be used.

### 7.1.1 Changing batteries



A battery change stops a measurement that is currently running. However, stored data is preserved.

#### CAUTION

**Incorrectly inserted batteries!  
The instrument may be damaged!**

- Pay attention to the polarity when inserting the batteries.



Only use new branded batteries. If a partially exhausted battery is inserted, the battery capacity will not be calculated correctly.

- 1 | Open battery compartment cover.



- 2 | Change batteries. Pay attention to polarity.



- 3 | Close the battery compartment.

## 8 Technical data

### 8.1 Online data loggers

#### Measurement-specific data



The humidity sensor attains the highest degree of accuracy in temperatures between + 5 °C and + 60 °C and 20% to 80% RH.

If the instrument is exposed to higher humidity for a long period of time, this can falsify the readings by up to 3% RH.

After 48 hours at 50% RH  $\pm$  10 % and +20 °C  $\pm$  5 °C, the sensor regenerates by itself. This process can be shortened to 12 hours by storing the sensor in a well-ventilated place at > 30°C and < 20% RH.

Online data loggers	testo 160 T	testo 160 TH	testo 160 E
Order number	0572 2019	0572 2021	0572 2022
<b>Temperature measurement</b>			
Sensor type	internal		see ext. probes
Measuring range	-30°C ... +50°C	-10°C ... +50°C	see ext. probes
Accuracy	$\pm$ 0.5 °C $\pm$ 1 digit		
Resolution	0.1 °C		
Response time	t90 (20K): < 20 min		
<b>Humidity measurement</b>			
Sensor type	internal		see ext. probes
Measuring range	0 to 100% RH (non-condensing)		see ext. probes
Accuracy	$\pm$ 2% RH @ 25 °C & 20 to 80% RH $\pm$ 3% RH @ 25 °C & <20% RH & >80% RH $\pm$ 1% RH hysteresis $\pm$ 1% RH/year drift		
Resolution	0.1% RH		
<b>Lux measurement</b>			
Measuring range			see ext. probes
Accuracy			
Resolution			
<b>UV measurement</b>			
Measuring range			see ext. probes
Accuracy			

Online data loggers	testo 160 T	testo 160 TH	testo 160 E
Resolution			



The time between the system warning "Battery almost discharged" and "Measurement data stop" is at the most one day during standard operation and a measuring cycle & communication cycle of 1 min (day & night) (battery type: Varta Industrial).

The online data loggers come with a factory calibration protocol as standard. For many application areas it is recommend to do a re-calibration every 12 months.

### General data

Online data loggers	testo 160 T	testo 160 TH	testo 160 E
Order number	0572 2019	0572 2021	0572 2022
Operating temperature	-30°C...+50°C	-10°C...+50°C	
Storage temperature	-30°C...+60°C	-20°C...+50°C	
Protection class	IP65	IP20	IP20
Measuring cycle	1 min to 24 h flexible		
Communication cycle	1 min to 24 h flexible		
Memory	32,000 readings (sum of all channels)		
Voltage supply	4 x AAA AIMng batteries 1.5 V Alternatively mains unit via USB connection For testo 160 T: If the data logger is to be used at temperatures below +10 °C, replace the existing batteries with lithium batteries (0515 1042).		
Battery life	18 months At +25 °C, 15-minute measuring cycle and 6-hour communication cycle (depending on the WLAN structure)		
Dimensions	76 x 64 x 25 mm	76 x 64 x 22 mm	76 x 64 x 22 mm
Weight including batteries	107 g	94 g	96 g

### WiFi-specific data

Online data loggers	testo 160 T	testo 160 TH	testo 160 E
Order number	0572 2019	0572 2021	0572 2022
<b>WLAN</b>			
Standard	802.11 b/g/n		
Security	WPA2 Enterprise: EAP-TLS, EAP-TTLS-TLS, EAP-TTLS-MSCHAPv2, EAP-TTLS-PSK, EAP-PEAP0-TLS, EAP-PEAP0-MSCHAPv2, EAP-PEAP0-PSK, EAP-PEAP1-TLS, EAP-PEAP1-MSCHAPv2, EAP-PEAP1-PSK; WPA Personal, WPA2 (AES), WPA (TKIP), WEP		

### Technical data for a secure wireless LAN

---



#### Ports

The testo 160 online data loggers use the MQTT protocol, which communicates via port TCP 8883.

These UDP port approvals are also required:

- Port 53 (DNS name resolution)
- Port 123 (NTP time synchronisation)

All ports only have to be able to communicate externally to the Cloud. No bi-directional port approvals are necessary.

---



During the initial configuration, it is possible to select whether DHCP or Static IP is used (select Expert mode for the corresponding information). (Not possible in the Setup assistant.)

---



#### testo Smart Connect Cloud

The testo Smart Connect Cloud is accessible via a normal, up-to-date browser (www). The standard TCP ports http (80) and https (443) are used.

---

## 8.2 External probes

### Measurement-specific data

Probes	S-TH	S-LuxUV	S-Lux
Order number	0572 2156	0572 2157	0572 2158
<b>Temperature measurement</b>			
Measuring range	-10 °C to 50 °C		
Accuracy	± 0.5 °C		
Resolution	0.1 °C		
<b>Humidity measurement</b>			
Measuring range	0 to 100 % RH (non-condensing)		
Accuracy	± 2% RH @ 25 °C & 20 to 80% RH ± 3% RH @ 25 °C & <20 % RH & >80% RH ± 1% RH hysteresis ± 1 % RH / year drift		
Resolution	0.1 % RH		
<b>Lux measurement</b>			
Measuring range		0 to 20,000 Lux	
Accuracy		DIN 5032-7 Class C-compliant. or: ± 3 lux or ± 3% of the reading (based on the external reference DIN 5032-7 Class L)	
Resolution		0.1 lux	
<b>UV measurement</b>			
Measuring range		0 to 10,000 mW/m <sup>2</sup>	
Accuracy		± 5 mW / m <sup>2</sup> or ± 5 % of the reading (based on the external reference at 22 °C)	
Resolution		0.1 mW/m <sup>2</sup>	

### General data

Probes	S-TH	S-Lux UV	S-Lux
Order number	0572 2156	0572 2157	0572 2158
Operating temperature	-10 °C to 50 °C		
Storage temperature	-20 °C to 50 °C		
Dimensions	38 x 16 mm	28 x 56 x 15 mm	28 x 56 x 15 mm
Weight	13 g	15 g	13 g

## 8.3 Deco-covers

### General data

Cover	
Order number	0554 2006
Use	testo 160 TH / testo 160 E
Dimensions	82 x 69 x 23 mm
Weight	22 g

## 9 Tips and assistance

### 9.1 Questions and answers

- **Can the online data logger be connected to the PC using any USB cable?**

We recommend that you use the USB cable supplied with the online data logger to guarantee stable data transmission. Longer USB cables are suitable for the power supply only.

- **Can the online data logger also be used in networks with WPA2 Enterprise encryption?**

testo 160 data loggers can be used in networks with the following WPA2 Enterprise encryption methods.

WPA2 Enterprise: EAP-TLS, EAP-TTLS-TLS, EAP-TTLS-MSCHAPv2, EAP-TTLS-PSK, EAP-PEAP0-TLS, EAP-PEAP0-MSCHAPv2, EAP-PEAP0-PSK, EAP-PEAP1-TLS, EAP-PEAP1-MSCHAPv2, EAP-PEAP1-PSK, WPA Personal, WPA2 (AES), WPA (TKIP), WEP

To integrate the loggers into the WPA2 Enterprise network, proceed as follows:

1. Open the PDF file stored on the logger and generate a corresponding XML file by selecting the programming options step by step.
2. Copy your company-specific WPA2 Enterprise certificates and the generated .XML file to the logger's mass storage via USB using drag & drop.
3. Please note that the configuration of the online data logger will only be fully transferred once the USB connector has been removed.



However, connections between the online data loggers and the testo Smart App are not possible in networks with WPA2 Enterprise encryption.

- **The XML configuration file is not being applied by the online data logger, what can I do?**

Depending on the operating system, there may be difficulties with the data transfer if the configuration file name has been changed. Leave the default file name.

- **The humidity sensor has been stored at a high temperature (> 30 °C) and in very high humidity (> 80% RH) for a long period of time, what can I do?**

The sensor requires a long period of time to regenerate itself again. This process can be accelerated by storing the sensor in a well-ventilated location at a high temperature (> 30 °C) and in low humidity (< 20% RH) for at least 12 hours.

- **The online data logger's wireless connection to the access point was interrupted, what can I do?**

1. Press the control key on the online data logger to start searching for a WLAN connection manually.

2. Change the alignment or position of the online data logger or the access point (WLAN router).

The error codes can be exported pressing the probe button for > 3 seconds. Then connect the data logger to the PC via USB cable. You can open or export the error report as CSV file.

- **The humidity measurement seems to provide incorrect readings. What can I do?**

The logger may have been exposed to too high an ambient humidity (>80 % RH) for too long. Especially in combination with high temperatures, this can affect the measurement signal of the humidity sensor. The sensor requires a longer period of time to regenerate. This process can be accelerated by storing the sensor well ventilated at high temperature (> 30°C) and low humidity (< 20 % rH) for at least 12 hours.

- **The CO<sub>2</sub> measurement seems to provide incorrect readings. What can I do?**

The CO<sub>2</sub> sensor is a precision optical measuring device. Vibrations and shocks may have changed the factory calibration. Recalibration can be carried out by Testo Industrial Services (TIS) or other certified service providers.

- **The calibration of the humidity sensor has failed. What can I do?**

When calibrating humidity sensors, ensure sufficiently long adjustment times and sufficient air circulation. You can find more information in the download area of the testo 160 series.

- **The online data logger is not reacting anymore on pressing the key. What can I do?**

You have to take out batteries and insert them again and then online data logger will work well again.

## 9.2 Status LED signals

The following table provides an overview of the meaning of the various status LED signals of the testo 160 online data logger.

Signal	Description
LED does not flash	Sleep mode
LED flashes green at one-second intervals (for 5 min, then 1 long red flash)	Configuration mode (hotspot) (key press > 6 sec)
LED gives 2 red flashes	Connection to WLAN failed (incorrect SSID, incorrect SSID password, incorrect account ID or incorrect account password, attempt to log the testo 160 E into the Cloud without any external probes connected.)

Signal	Description
LED gives 1 long green flash	Configuration via USB/PDF successful (XML is correct)
LED gives 3 red flashes	Configuration via USB/PDF failed (XML is incorrect)
LED gives 2 green flashes	Connection to WLAN and Cloud successful
LED gives 1 long red flash	Alarm activated due to limit value violation
LED gives 5 green flashes	Reset online data logger to factory settings (key pressed > 20 sec)
LED gives 1 green flash (measurement data collected)	Send measurement data to the Testo Cloud (website): press key < 3 sec
LED gives 2 short green flashes (measurement data transmitted)	Measurement data transmitted successfully
LED flashes alternately green and red	Firmware update via USB or wireless
LED flashes red 4 times for a long time.	Press the button on the front of the logger briefly (< 1 sec). If the online data logger flashes red 4 times again, the batteries are exhausted and must be replaced.

## 9.2.1 Key functions

The key on the online data logger has different functions depending on how long it is pressed:

Key operation	Function
Press the key > 1 s	<ul style="list-style-type: none"> <li>- Not configured data logger: start configuration mode</li> <li>- Configured data logger: start measurement and communication mode</li> </ul>
Press the key > 3 s	Start recording of log file, to export this via USB cable.
Press the key > 6 s	Restart configuration mode (for already configured data loggers)
Press the key > 20 s	Reset the online data logger to factory settings.



**Testo SE & Co. KGaA**  
Celsiusstraße 2  
79822 Titisee-Neustadt  
Germany  
Telefon: +49 7653 681-0  
E-Mail: [info@testo.de](mailto:info@testo.de)  
Internet: [www.testo.com](http://www.testo.com)